

The data to be read in conjunction with the Hydrogen Thyatron Preamble.

DESCRIPTION

The FX2536 is a rugged hydrogen thyatron designed for use in compact radars and in general pulse modulator applications. It has a ceramic envelope with a mounting flange and flying lead connections. The tube is a commercial version of the 7665.

It features low jitter and low anode delay time and is suitable for use at high pulse repetition rates; it can switch peak powers up to 3 MW. The tube will operate over an ambient temperature range of -55 to $+130$ °C. A hydrogen reservoir is incorporated.

Peak forward anode voltage	16	kV max
Peak inverse anode voltage	16	kV max
Peak anode current	350	A max
Average anode current	500	mA max
Rate of rise of anode current	2000	A/ μ s max
Anode heating factor	5×10^9	VApps max

GENERAL

Electrical

Cathode (connected internally to one end of heater)	oxide coated
Heater voltage	$6.3 \pm 7.5\%$ V
Heater current	4.3 A
Reservoir voltage	$6.3 \pm 7.5\%$ V
Reservoir current	2.0 A
Tube heating time (minimum)	3.0 min

Mechanical

Seated height	63.5 mm (2.500 inches) max
Clearance required below mounting flange	31.75 mm (1.250 inch) min
Overall diameter (mounting flange)	57.15 mm (2.250 inches) max
Net weight	250 g (0.55 pound) approx
Mounting position	any
Base	flange mounting

Cooling natural or forced-air
 When operating at maximum anode dissipation, forced-air cooling up to $0.14 \text{ m}^3/\text{min}$ ($5 \text{ ft}^3/\text{min}$) should be directed into the anode cup.



PULSE MODULATOR SERVICE MAXIMUM AND MINIMUM RATINGS (Absolute values)

	Min	Max	
Anode			
Peak forward anode voltage (see note 1)	-	16	kV
Peak inverse anode voltage (see note 2)	-	16	kV
Peak anode current	-	350	A
Average anode current	-	500	mA
Rate of rise of anode current (see note 3)	-	2000	A/ μ s
Anode heating factor	-	5×10^9	VApps

MAXIMUM AND MINIMUM RATINGS (Continued)

	Min	Max	
Grid			
Unloaded grid drive pulse voltage (see note 4)	200	600	V
Grid pulse duration	2.0	-	μs
Rate of rise of grid pulse (see note 3)	300	-	V/μs
Peak inverse grid voltage	-	200	V
Loaded grid bias voltage	0	-120	V
Forward impedance of grid drive circuit	50	500	Ω

Heaters

Cathode heater voltage	6.3 ± 7.5%	V
Reservoir heater voltage	6.3 ± 7.5%	V
Tube heating time	3.0	min

Environmental

Environmental performance	see note 5	
Ambient temperature	-55	+130 °C
Altitude	-	10 000 ft
	-	3 km

CHARACTERISTICS

	Min	Typical	Max	
Critical DC anode voltage for conduction (see note 6)	-	0.4	1.0	kV
Anode delay time (see notes 6 and 7)	-	0.25	0.4	μs
Anode delay time drift (see notes 6 and 8)	-	0.05	0.1	μs
Time jitter (see notes 6 and 9)	-	3.0	5.0	ns
Heater current (at 6.3 V)	3.5	4.3	6.0	A
Reservoir current (at 6.3 V)	1.0	2.0	4.0	A

NOTES

1. This is the maximum forward hold-off voltage imposed on the thyatron in a pulse modulator circuit. Tubes are tested at 18 kV peak forward anode voltage with the charging reactor inductance and pulse forming network capacitance resonant at 1000 pps. For instantaneous starting applications the maximum permissible peak forward voltage is 16 kV; this must not be reached in less than 0.04 second and there must be no overshoot.
2. In pulsed operation the peak inverse anode voltage, exclusive of a spike of 0.05 μs maximum duration, must not exceed 5.0 kV during the first 25 μs after the pulse.
3. This rate of rise refers to that part of the leading edge of the pulse between 25% and 75% of the pulse amplitude.

4. Measured with respect to cathode potential.
5. The tubes are subjected to the following tests on a sampling basis.
 - (a) **Vibration** - The tubes are vibrated at 10 g in each of 3 planes through the range 10 to 50 Hz and back again to 10 Hz in 10 minutes whilst looking for resonances in the range 0 to 2000 Hz.
 - (b) **Long Duration Shock** - The tubes are tested at 100 g for 11 ms with 3 blows in each plane.
 - (c) **High Temperature Test** - The tubes are tested at an ambient temperature of 150 °C under normal operating conditions for 5 hours.
6. The typical figures are obtained on test using conditions of minimum grid drive. Improved performance can be expected by increasing the grid drive.
7. The time interval between a point on the leading edge of the unloaded grid pulse at 25% of the pulse amplitude and the point where anode conduction takes place.
8. Normally taken as the drift in delay time over an 8-minute run at full ratings between the second and tenth minutes of operation.
9. The variation of firing time measured at 50% of current pulse amplitude.

HEALTH AND SAFETY HAZARDS

Marconi Applied Technologies hydrogen thyratrons are safe to handle and operate, provided that the relevant precautions stated herein are observed. Marconi Applied Technologies does not accept responsibility for damage or injury resulting from the use of electronic devices it produces. Equipment manufacturers and users must ensure that adequate precautions are taken. Appropriate warning labels and notices must be provided on equipments incorporating Marconi Applied Technologies devices and in operating manuals.



High Voltage

Equipment must be designed so that personnel cannot come into contact with high voltage circuits. All high voltage circuits and terminals must be enclosed and fail-safe interlock switches must be fitted to disconnect the primary power supply and discharge all high voltage capacitors and other stored charges before allowing access. Interlock switches must not be bypassed to allow operation with access doors open.



X-Ray Radiation

All high voltage devices produce X-rays during operation and may require shielding. The X-ray radiation from hydrogen thyratrons is usually reduced to a safe level by enclosing the equipment or shielding the thyatron with at least 1.6 mm (¹/₁₆ inch) thick steel panels.

Users and equipment manufacturers must check the radiation level under their maximum operating conditions.

OUTLINE

(All dimensions without limits are nominal)

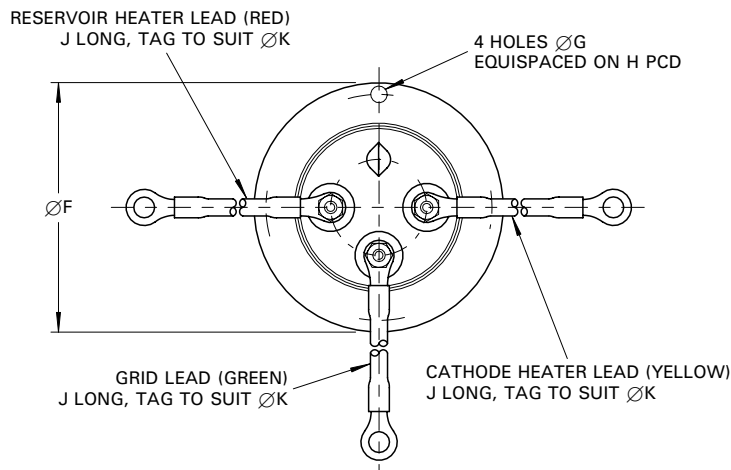
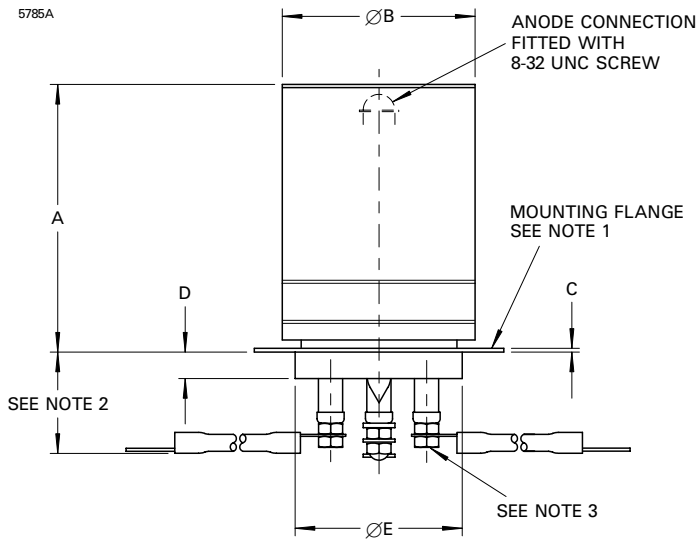

Ref	Millimetres	Inches
A	62.23 ± 0.51	2.450 ± 0.020
B	44.45 ± 0.25	1.750 ± 0.010
C	0.76	0.030
D	7.11 max	0.280 max
E	38.1 max	1.500 max
F	57.15 ± 0.13	2.250 ± 0.005
G	4.19	0.165
H	51.6	2.031
J	152.4	6.000
K	5.16	0.203

Inch dimensions have been derived from millimetres.

Outline Notes

1. The mounting flange is the connection for the cathode, cathode heater return and reservoir heater return.
2. A minimum clearance of 31.75 mm (1.250 inches) must be allowed below the mounting flange.
3. Where Marconi Applied Technologies gives prior agreement to the use of alternative lead/mounting arrangements on these posts, great care must be taken to avoid damaging the threads and the metal/ceramic joints. A flat wrench must be used to hold the nut nearest the ceramic while a torque wrench, set to a value of less than 0.046 kg-m (4 lb-in), is used on the other nut.

Whilst Marconi Applied Technologies has taken care to ensure the accuracy of the information contained herein it accepts no responsibility for the consequences of any use thereof and also reserves the right to change the specification of goods without notice. Marconi Applied Technologies accepts no liability beyond that set out in its standard conditions of sale in respect of infringement of third party patents arising from the use of tubes or other devices in accordance with information contained herein.