

The data to be read in conjunction with the Hydrogen Thyatron Preamble.

ABRIDGED DATA

Deuterium-filled flange mounted tetrode thyatron featuring low jitter and low anode delay time drift. It is designed for applications requiring high rate of rise of current and a high ampere-second capability. It is suitable for use at high pulse repetition rates. A reservoir operating from a separate heater supply is incorporated.

Peak forward anode voltage	35	kV max
Peak anode current	1500	A max
Average anode current	1.5	A max

GENERAL

Electrical

Cathode (connected internally to one end of heater)	oxide coated	
Cathode heater voltage	6.3 ± 5%	V
Cathode heater current	21.5	A
Reservoir heater voltage (see note 1)	6.3 ± 5%	V
Reservoir heater current	8.0	A
Tube heating time (minimum)	5.0	min
Inter-electrode capacitances (approximate):		
anode to grid 2 (grid 1 and cathode not connected)	13	pF
anode to grid 1 (grid 2 and cathode not connected)	7.5	pF
anode to cathode (grid 1 and grid 2 not connected)	26	pF

Mechanical

Seated height	210.6 mm (8.250 inches)	nom
Clearance required below mounting flange	50.8 mm (2.000 inches)	min
Overall diameter	111.1 mm (4.375 inches)	nom
Net weight	0.8 kg (1.75 pounds)	approx
Mounting position (see note 2)	any	
Top cap connector (see note 3)	MA359 or MA360A	

Cooling

Forced-air or liquid (oil or coolant immersion). See note 4 and Preamble.

Maximum temperature of envelope	200	°C
---	-----	----

Natural ambient cooling is not sufficient to maintain the envelope, especially the tube base, below the maximum temperature specified. A satisfactory base temperature is around 100 °C.



**PULSE MODULATOR SERVICE
 MAXIMUM AND MINIMUM RATINGS
 (Absolute values)**

	Min	Max	
Anode			
Peak forward anode voltage (see note 5)	-	35	kV
Peak inverse anode voltage (see note 6)	-	25	kV
Peak anode current	-	1500	A
Average anode current	-	1.5	A
Rate of rise of anode current (see note 7)	-	5000	A/μs

MAXIMUM AND MINIMUM RATINGS (continued)

	Min	Max	
Grid 2			
Unloaded grid 2 drive pulse voltage (see note 8)	200	1000	V
Grid 2 pulse duration	1.0	-	μs
Rate of rise of grid 2 pulse (see note 7)	1.0	-	kV/μs
Grid 2 pulse delay	0.5	3.0	μs
Peak inverse grid 2 voltage	-	450	V
Loaded grid 2 bias voltage	-50	-150	V
Forward impedance of grid 2 drive circuit	50	800	Ω

Grid 1 – DC Primed (See note 9)

DC grid 1 unloaded priming voltage	75	150	V
DC grid 1 priming current	50	100	mA

Grid 1 – Pulsed

Unloaded grid 1 drive pulse voltage (see note 8)	300	1000	V
Grid 1 pulse duration	2.0	-	μs
Rate of rise of grid 1 pulse (see note 7)	1.0	-	kV/μs
Peak inverse grid 1 voltage	-	450	V
Loaded grid 1 bias voltage	see note 10		
Peak grid 1 drive current	0.3	1.0	A

Heaters

Cathode heater voltage	6.3 ± 5%		V
Reservoir heater voltage (see note 1)	6.3 ± 5%		V
Tube heating time	5.0	-	min

Environmental

Ambient temperature	-50	+90	°C
Altitude	-	3	km
	-	10 000	ft

CHARACTERISTICS

	Min	Typical	Max	
Critical DC anode voltage for conduction (see note 11)	-	0.5	2.0	kV
Anode delay time (see notes 11 and 12)	-	0.15	0.25	μs
Anode delay time drift (see notes 11 and 13)	-	20	50	ns
Time jitter (see note 11)	-	1.0	5.0	ns
Cathode heater current (at 6.3 V)	18	22	25	A
Reservoir heater current (at 6.3 V)	6.5	8.0	9.5	A

RATINGS FOR SINGLE SHOT OR CROWBAR SERVICE (See note 9)

DC forward anode voltage	30	kV max
Peak anode current	15 000	A max
Product of peak current and pulse duration	0.6	A.s max
Repetition frequency	1 pulse per 10 s	max

NOTES

- The reservoir heater must be decoupled with a suitable capacitor to avoid damage by spike voltages.
- The tube must be mounted by its mounting flange.
- A large area anode connector, Marconi Applied Technologies type MA360A, is recommended for high average currents.
- An adequate flow of air must be supplied to maintain the glass/metal envelope temperature below the maximum rated value of 200 °C but preferably below 100 °C for the tube base.
- The maximum permissible peak forward voltage for instantaneous starting is 35 kV and there must be no overshoot.
- The peak inverse voltage including spike must not exceed 10 kV for the first 25 μs after the anode pulse. Amplitude and rate of rise of inverse voltage contribute greatly to tube dissipation and electrode damage; if these are not minimised in the circuit, tube life will be shortened considerably. The aim should be for an inverse voltage of 3 – 5 kV peak with a rise time of 0.5 μs.
- This rate of rise refers to that part of the leading edge of the pulse between 25% and 75% of the pulse amplitude.
- Measured with respect to cathode. In certain cases the maximum drive pulse voltage may be exceeded without damage to the tube; a maximum value of 2.5 kV is then recommended. When grid 1 is pulse driven, the last 0.25 μs of the top of the grid 1 pulse must overlap the corresponding first 0.25 μs of the top of the delayed grid 2 pulse. A grid 1 pre-pulse is recommended for maximum tube life.
- When DC priming is used on grid 1, a negative bias of 100 to 200 V must be applied to grid 2 to ensure anode voltage hold-off. DC priming is recommended for crowbar service.
- DC negative bias voltages must not be applied to grid 1. When grid 1 is pulse driven, the potential of grid 1 may vary between -10 and +5 V with respect to cathode potential during the period between the completion of recovery and the commencement of the succeeding grid pulse.
- Typical figures are obtained on test using conditions of minimum grid drive. Improved performance can be expected by increasing the grid drive.
- The time interval between the instant at which the rising unloaded grid 2 pulse reaches 25% of its pulse amplitude and the instant when anode conduction takes place.
- The drift in delay time over a period from 10 seconds to 10 minutes after reaching full voltage.

HEALTH AND SAFETY HAZARDS

Marconi Applied Technologies hydrogen thyratrons are safe to handle and operate, provided that the relevant precautions stated herein are observed. Marconi Applied Technologies does not accept responsibility for damage or injury resulting from the use of electronic devices it produces. Equipment manufacturers and users must ensure that adequate precautions are taken. Appropriate warning labels and notices must be provided on equipments incorporating Marconi Applied Technologies devices and in operating manuals.



High Voltage

Equipment must be designed so that personnel cannot come into contact with high voltage circuits. All high voltage circuits

and terminals must be enclosed and fail-safe interlock switches must be fitted to disconnect the primary power supply and discharge all high voltage capacitors and other stored charges before allowing access. Interlock switches must not be bypassed to allow operation with access doors open.



X-Ray Radiation

All high voltage devices produce X-rays during operation and may require shielding. The X-ray radiation from hydrogen thyratrons is usually reduced to a safe level by enclosing the equipment or shielding the thyratron with at least 1.6 mm ($\frac{1}{16}$ inch) thick steel panels.

Users and equipment manufacturers must check the radiation level under their maximum operating conditions.

SCHEMATIC DIAGRAM

7961

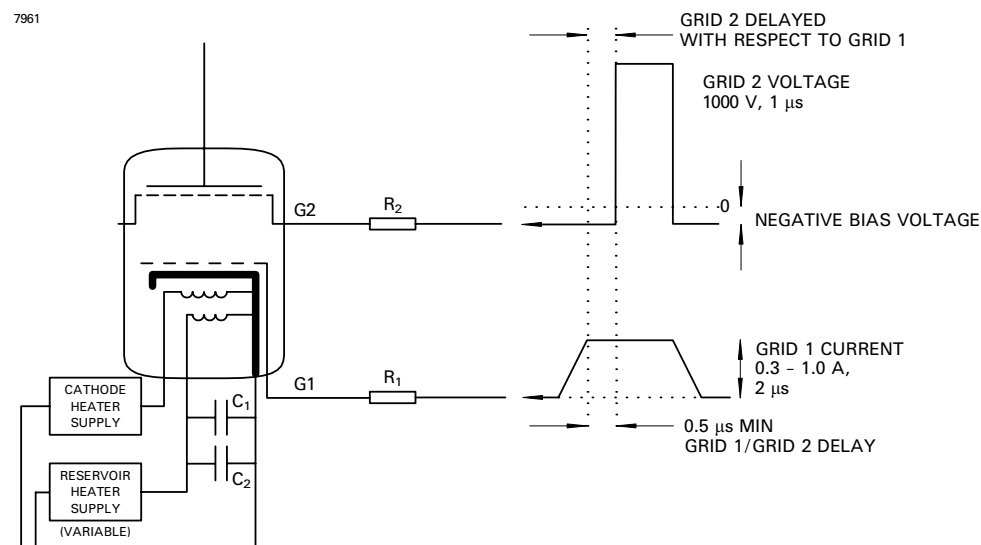

RECOMMENDED GRID, CATHODE AND RESERVOIR HEATER CONNECTIONS

- R_1 = Grid 1 series resistor. 12 W vitreous enamelled wirewound is recommended, of an impedance to match the grid 1 drive pulse current.
- R_2 = Grid 2 series resistor. 12 W vitreous enamelled wirewound is recommended, of an impedance to match the grid 2 drive pulse circuit.
- C_1, C_2 — reservoir protection capacitors with a voltage rating ≥ 500 V;
 - C_1 = 1000 pF low inductance (e.g. ceramic),
 - C_2 = 1 μ F (e.g. polycarbonate or polypropylene).

Components R_1 , R_2 , C_1 and C_2 should be mounted as close to the tube as possible.

OUTLINE

(All dimensions without limits are nominal)

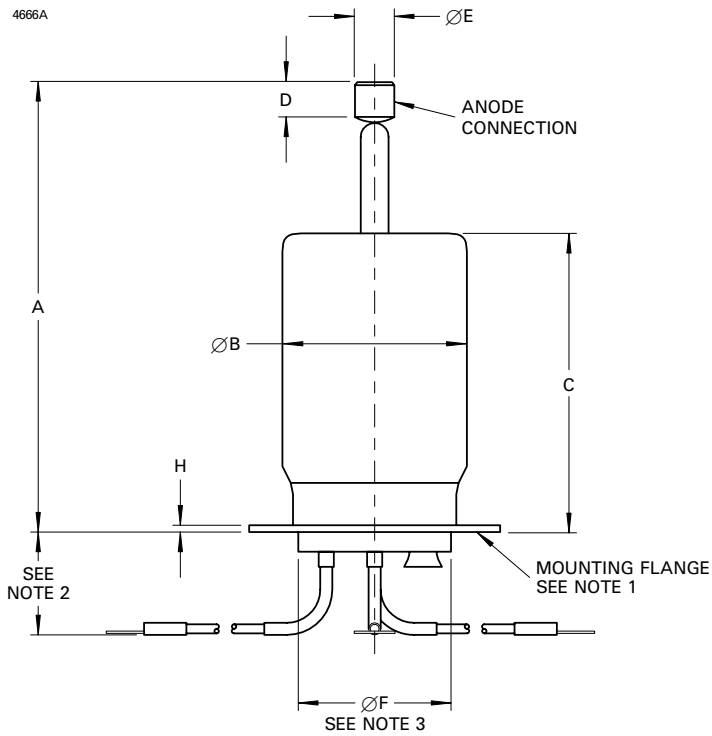

Ref	Millimetres	Inches
A	209.6	8.250
B	84.17 max	3.314 max
C	130.0	5.118
D	12.7 min	0.500 min
E	14.38 ± 0.18	0.566 ± 0.007
F	69.85 max	2.750 max
G	50.8 min	2.000 min
H	2.5	0.098
J	190.5 min	7.500 min
K	6.35	0.250
L	111.1	4.375
M	95.25	3.750
N	6.5	0.256

Inch dimensions have been derived from millimetres.

Outline Notes

1. The mounting flange is the connection for the cathode, cathode heater return and reservoir heater return.
2. A minimum clearance of 50.8 mm (2.000 inches) must be allowed below the mounting flange.
3. The recommended mounting hole is 73.03 mm (2.875 inches) diameter.

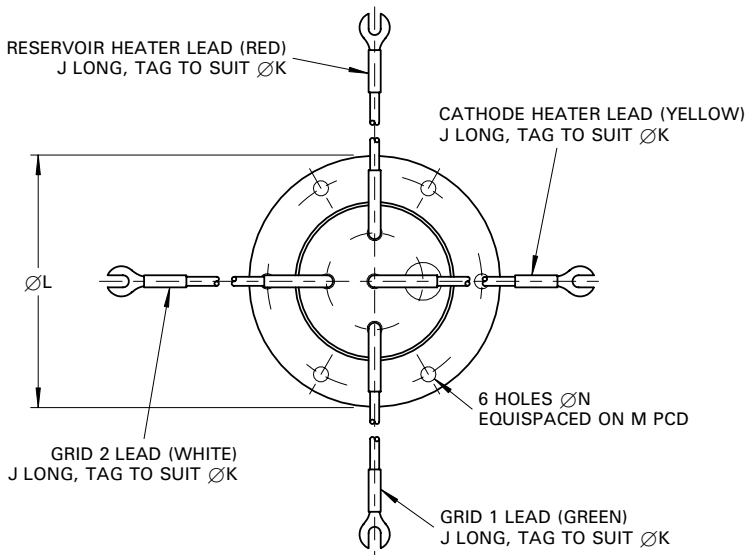

Whilst Marconi Applied Technologies has taken care to ensure the accuracy of the information contained herein it accepts no responsibility for the consequences of any use thereof and also reserves the right to change the specification of goods without notice. Marconi Applied Technologies accepts no liability beyond that set out in its standard conditions of sale in respect of infringement of third party patents arising from the use of tubes or other devices in accordance with information contained herein.