

The data to be read in conjunction with the Hydrogen Thyatron Preamble.

**ABRIDGED DATA**

Deuterium-filled tetrode thyatron with ceramic/metal envelope, featuring fast recovery time, low jitter, firing time and drift. This tube has been developed specifically to give improved performance over the CX1154 in magnetron and klystron pulse modulators.

Peak forward anode voltage . . . . .	35	kV max
Peak anode current . . . . .	3.0	kA max
Average anode current . . . . .	2.0	A max

**GENERAL DATA**

**Electrical**

Cathode (connected internally to one end of heater) . . . . .	oxide coated
Cathode heater voltage . . . . .	6.3 <sup>+ 0.5</sup> / <sub>- 0.0</sub> V
Cathode heater current . . . . .	22.5 A
Reservoir heater voltage (see note 1) . . . . .	5.5 V
Reservoir heater current . . . . .	7.0 A
Tube heating time (minimum) . . . . .	15 min
Anode to grid 2 capacitance . . . . .	15 to 20 pF

**Mechanical**

Seated height . . . . .	165.1 mm (6.500 inches) max
Clearance required below mounting flange . . . . .	38.1 mm (1.500 inches) min
Overall diameter (mounting flange) . . . . .	111.1 mm (4.375 inches) nom
Net weight . . . . .	1.8 kg (4 pounds) approx
Mounting position (see note 2) . . . . .	any
Tube connections . . . . .	see outline

**Cooling**

liquid or forced-air	
Liquid . . . . .	oil or coolant immersion
Forced-air . . . . .	see below

Cooling by oil or coolant immersion is preferred in view of the high voltages present. Further information is contained in the relevant section of the Preamble.

The tube may be cooled by forced-air directed mainly onto the base, and the metal/ceramic envelope should be maintained below the maximum rated temperature. An air flow of at least 2.83 m<sup>3</sup>/min (100 ft<sup>3</sup>/min), depending on the mechanical layout, will be necessary to keep the tube operating temperatures under the limits specified below.

In addition to 200 W of heater power, the tube dissipates from 100 W per ampere average anode current, rising to 300 W/A at the highest rates of rise and fall of anode current.



The cathode end of the tube must be cooled whenever heater voltages are applied, since the cathode flange will reach a temperature of 120 °C above ambient in the absence of cooling.

Envelope temperature:

ceramic, anode and grids . . . . .	150	°C max
cathode flange and base . . . . .	120	°C max

## MAXIMUM AND MINIMUM RATINGS (Absolute values)

These ratings cannot necessarily be used simultaneously, and no individual rating must be exceeded.

	Min	Typical	Max	
<b>Anode (Pulse Modulator Service)</b>				
Peak forward anode voltage (see note 3)	-	-	35	kV
Peak inverse anode voltage (see note 4)	-	-	35	kV
Peak anode current	-	3.0	-	kA
Peak anode current (pulse repetition rate limited to 60 pps max)	-	-	4.0	kA
Average anode current	-	-	2.0	A
Rate of rise of anode current (see notes 5 and 6)	-	10	-	kA/ $\mu$ s
Pulse repetition rate	-	400	-	pps

	Min	Max	
<b>Anode (Single-Shot or Fault Condition)</b>			
DC forward anode voltage	-	30	kV
Peak anode current	-	10	kA
Rate of rise of anode current	-	see note 5	
Total conducted charge:			
capacitor discharge	-	0.1	C
power supply follow-on (see note 7)	-	4	C
Repetition frequency	1 pulse per 10 s	max	

### Grid 2

Unloaded grid 2 drive pulse voltage (see note 8)	500	2000	V
Grid 2 pulse duration	0.5	-	$\mu$ s
Rate of rise of grid 2 pulse (see note 6)	10	-	kV/ $\mu$ s
Grid 2 pulse delay	0.5	3.0	$\mu$ s
Peak inverse grid 2 voltage	-	450	V
Loaded grid 2 bias voltage	0	-150	V
Forward impedance of grid 2 drive circuit	50	500	$\Omega$

### Grid 1 - Pulsed

Peak grid 1 drive current (see note 9)	1.0	5.0	A
Unloaded grid 1 drive pulse voltage (see note 8)	300	1000	V
Grid 1 pulse duration	2.0	-	$\mu$ s
Rate of rise of grid 1 pulse (see note 6)	1.0	-	kV/ $\mu$ s
Peak inverse grid 1 voltage	-	450	V
Loaded grid 1 bias voltage	-	see note 10	

### Grid 1 - DC Primed (See note 10)

DC grid 1 unloaded priming voltage	75	150	V
DC grid 1 priming current	75	150	mA

### Cathode

Heater voltage	6.3	6.8	V
Heating time	15	-	min

### Reservoir

Heater voltage (see note 1)	5.0	6.0	V
Heating time	15	-	min

### Environmental

Ambient temperature	-50	+90	$^{\circ}$ C
Altitude	-	3	km
	-	10 000	ft

## CHARACTERISTICS

	Min	Typical	Max	
Critical DC anode voltage for				
conduction (see note 11)	-	0.5	1.0	kV
Anode delay time				
(see notes 11 and 12)	-	0.15	0.25	$\mu$ s
Anode delay time drift				
(see notes 11 and 13)	-	15	50	ns
Time jitter (see note 11)	-	1.0	5.0	ns
Recovery time	-	see graph on page 5	-	
Cathode heater current				
(at 6.3 V)	20	22.5	25	A
Reservoir heater current				
(at 5.5 V)	6.0	7.0	8.0	A

## NOTES

1. The reservoir heater must be decoupled with a suitable capacitor to avoid damage by spike voltages. The recommended reservoir heater voltage for each individual tube is stamped on the tube envelope. This recommended value is determined for operation at the maximum anode voltage under modulator conditions. For lower voltages and DC operation the reservoir heater voltage should be changed to a value consistent with voltage hold-off at the operating level. Maximum reservoir voltage (i.e. maximum gas pressure in the tube) is one prerequisite for maximum thyratron life. The reservoir voltage should be stabilised to  $\pm 0.1$  V.
2. The tube must be fitted using its mounting flange.
3. Under resonant charging conditions a maximum anode voltage of 35 kV is recommended. Using command charging conditions where the voltage appears at the anode for only a short time (<1 ms), this thyratron may be operated up to 40 kV.
4. The peak inverse voltage including spike must not exceed 10 kV for the first 125  $\mu$ s after the anode pulse.
5. In single shot or burst mode, this parameter can exceed 150 kA/ $\mu$ s. The ultimate value which can be attained depends to a large extent upon the external circuit.
6. This rate of rise refers to that part of the leading edge of the pulse between 25% and 75% of the pulse amplitude.
7. Under fault conditions, most of the coulombs are often in the power supply follow-on current, rather than the storage capacitor discharge.
8. Measured with respect to cathode. Pre-pulsing of grid 1 is recommended for modulator and high rate of rise of current applications. The last 0.25  $\mu$ s of the top of the grid 1 pulse must overlap the corresponding first 0.25  $\mu$ s of the top of the delayed grid 2 pulse.

9. The higher grid 1 is pulsed, the larger must the grid 2 negative bias be, to prevent the tube firing on the grid 1 pulse.
10. DC negative bias voltages must not be applied to grid 1. When grid 1 is pulse driven, the potential of grid 1 may vary between  $-10$  and  $+5$  V with respect to cathode potential during the period between the completion of recovery and the commencement of the succeeding grid pulse.
11. Typical figures are obtained on test using conditions of minimum grid drive. Improved performance can be expected by increasing grid drive.
12. The time interval between the instant at which the rising unloaded grid 2 pulse reaches 25% of its pulse amplitude and the instant when anode conduction takes place.
13. The drift in delay time over a period from 10 seconds to 10 minutes after reaching full voltage.

## HEALTH AND SAFETY HAZARDS

Marconi Applied Technologies hydrogen thyratrons are safe to handle and operate, provided that the relevant precautions stated herein are observed. Marconi Applied Technologies does not accept responsibility for damage or injury resulting from the use of electronic devices it produces. Equipment manufacturers and users must ensure that adequate precautions are taken. Appropriate warning labels and notices must be provided on equipments incorporating Marconi Applied Technologies devices and in operating manuals.



### High Voltage

Equipment must be designed so that personnel cannot come into contact with high voltage circuits. All high voltage circuits and terminals must be enclosed and fail-safe interlock switches must be fitted to disconnect the primary power supply and discharge all high voltage capacitors and other stored charges before allowing access. Interlock switches must not be bypassed to allow operation with access doors open.



### X-Ray Radiation

All high voltage devices produce X-rays during operation and may require shielding. The X-ray radiation from hydrogen thyratrons is usually reduced to a safe level by enclosing the equipment or shielding the thyatron with at least  $\frac{1}{16}$ -inch (1.6 mm) thick steel panels.

Users and equipment manufacturers must check the radiation level under their maximum operating conditions.

## SCHEMATIC DIAGRAM

7543

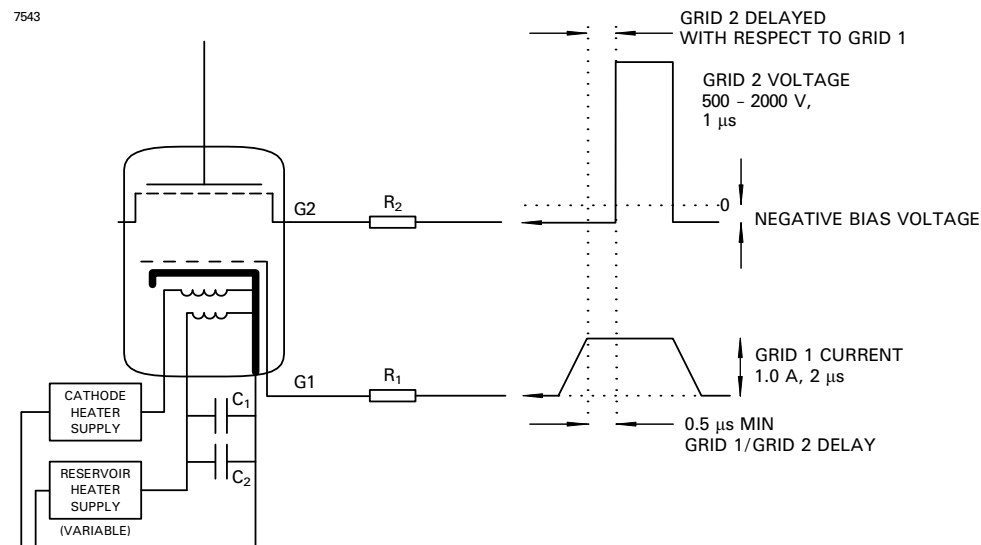

## RECOMMENDED GRID, CATHODE AND RESERVOIR HEATER CONNECTIONS

- $R_1$  = Grid 1 series resistor. 12 W vitreous enamelled wirewound is recommended, of a total impedance to match the grid 1 drive pulse circuit.
- $R_2$  = Grid 2 series resistor. 12 W vitreous enamelled wirewound is recommended, of an impedance to match the grid 2 drive pulse circuit.
- $C_1, C_2$  = reservoir protection capacitors with a voltage rating  $\geq 500$  V;
- $C_1$  = 1000 pF low inductance (e.g. ceramic),
- $C_2$  = 1  $\mu$ F (e.g. polycarbonate or polypropylene).

Components  $R_1$ ,  $R_2$ ,  $C_1$  and  $C_2$  should be mounted as close to the tube as possible.

# OUTLINE

(All dimensions without limits are nominal)

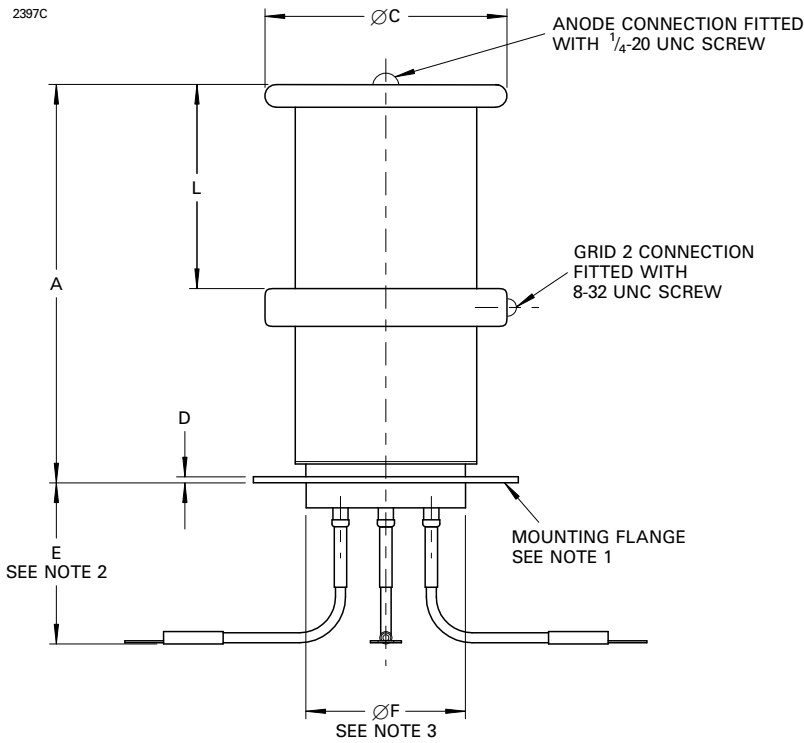

Ref	Millimetres	Inches
A	165.1 max	6.500 max
B	111.13	4.375
C	101.6	4.000
D	2.54	0.100
E	50.8 min	2.000 min
F	69.85 max	2.750 max
G	190.5 min	7.500 min
H	6.35	0.250
J	6.50	0.256
K	95.25	3.750
L	85.73	3.375

Inch dimensions have been derived from millimetres.

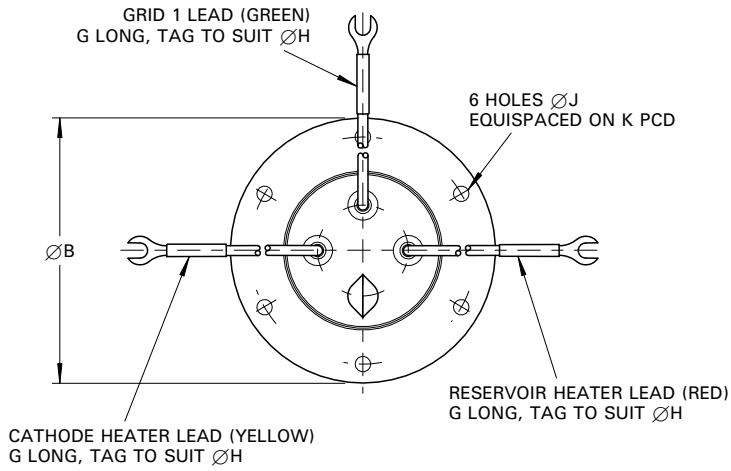

## Outline Notes

1. The mounting flange is the connection for the cathode, cathode heater return and reservoir heater return.
2. A minimum clearance of 38.1 mm (1.500 inches) must be allowed below the mounting flange.
3. The recommended mounting hole is 73.0 mm (2.875 inches) diameter.

# TYPICAL RECOVERY CHARACTERISTICS (Reservoir voltage 5.5 V)

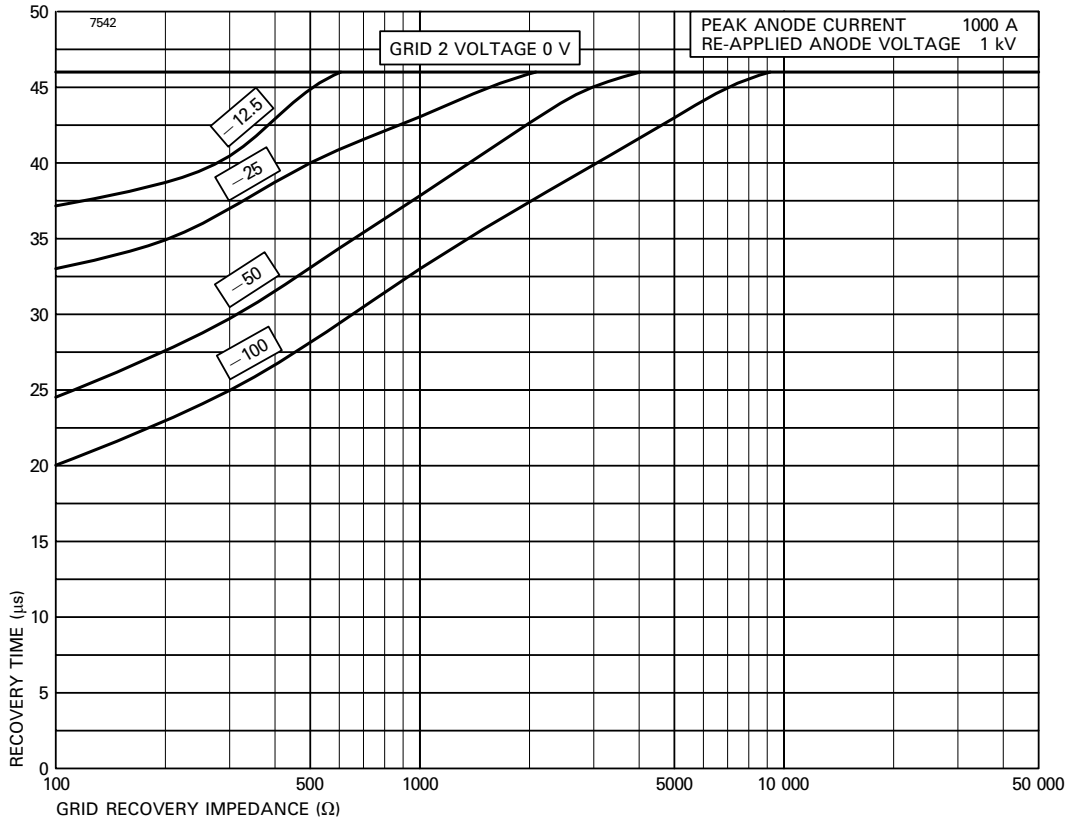

Whilst Marconi Applied Technologies has taken care to ensure the accuracy of the information contained herein it accepts no responsibility for the consequences of any use thereof and also reserves the right to change the specification of goods without notice. Marconi Applied Technologies accepts no liability beyond that set out in its standard conditions of sale in respect of infringement of third party patents arising from the use of tubes or other devices in accordance with information contained herein.