

The data to be read in conjunction with the Hydrogen Thyatron Preamble.

ABRIDGED DATA

Hydrogen-filled triode thyatron, positive grid, for pulse operation. A hydrogen reservoir is incorporated. Environmental tests applied to the tube include linear acceleration at 12 g, and vibration at $1/4$ g minimum acceleration and 150 Hz frequency or at the frequency of maximum resonance in the range between 10 and 150 Hz.

Peak forward anode voltage	20	kV max
Peak anode current	325	A max
Average anode current	500	mA max
Anode heating factor	3.9×10^9	VApps max
Peak output power	2.6	MW max

GENERAL

Electrical

Cathode (connected internally to one end of heater)	oxide coated
Heater voltage	$6.3 \pm 7.5\%$ V
Heater current	10.6 A
Tube heating time (minimum)	3.0 min

Mechanical

Overall length	222.3 mm (8.750 inches) max
Overall diameter	65.1 mm (2.563 inches) max
Net weight	350 g (12 ounces) approx
Mounting position	any
Clamping	see note 1
Base	B4D, bayonet
Top cap	BS448-CT3

Cooling	natural
-------------------	---------

PULSE MODULATOR SERVICE MAXIMUM AND MINIMUM RATINGS (Absolute values)

	Min	Max
Anode		
Peak forward anode voltage (see note 2)	-	20 kV
Peak inverse anode voltage (see note 3)	-	20 kV
Peak anode current	-	325 A
Average anode current	-	500 mA
Rate of rise of anode current (see note 4)	-	1500 A/ μ s
Anode heating factor	-	3.9×10^9 VApps

	Min	Max
Grid		
Unloaded grid drive pulse voltage (see note 5)	200	- V
Grid pulse duration	2.0	- μ s
Rate of rise of grid pulse (see note 4)	180	- V/ μ s
Peak inverse grid voltage	-	200 V
Loaded grid bias voltage	0	-120 V
Forward impedance of grid drive circuit	50	500 Ω

Cathode

Heater voltage	$6.3 \pm 7.5\%$	V
Tube heating time	3.0	- min

Environmental

Environmental performance	see note 6
Ambient temperature	-50 +90 $^{\circ}$ C
Altitude	- 3 km
	- 10 000 ft

CHARACTERISTICS

	Min	Typical	Max
Critical DC anode voltage for conduction (see note 7)	-	0.3	1.0 kV
Anode delay time (see notes 7 and 8)	-	0.3	0.65 μ s
Anode delay time drift (see notes 7 and 9)	-	0.05	0.1 μ s
Time jitter (see notes 7 and 10)	-	5.0	10.0 ns
Recovery time	see note 11 and curves		
Heater current (at 6.3 V)	9.6	10.6	11.6 A

NOTES

- The tube should preferably be clamped by the base only. Any clamps used on the bulb must not extend beyond 108 mm (4 1/4 inches) above the top of the base and should be made from material of low thermal conductivity.
- This is the maximum forward hold-off voltage imposed on the thyatron in a pulse modulator circuit. All tubes are tested at 20 kV peak forward anode voltage, with the charging reactor inductance and pulse forming network capacitance resonant at 1000 pps.
For instantaneous starting applications the maximum permissible peak forward voltage is 13.5 kV; this must not be reached in less than 0.04 seconds and there must be no overshoot.
- In pulsed operation the peak inverse anode voltage, exclusive of a spike of 0.05 μ s duration, must not exceed 5.0 kV during the first 25 μ s after the pulse.
- This rate of rise refers to that part of the leading edge of the pulse between 25% and 75% of the pulse amplitude.
- Measured with respect to cathode potential.
- All tubes are subjected to an acceleration of 10 g at 50 Hz before testing.
- The typical figures are obtained on test using conditions of minimum grid drive. Improved performance can be expected by increasing the grid drive.
- The time interval between a point on the leading edge of the unloaded grid pulse at 25% of the pulse amplitude and the point where anode conduction takes place.
- Normally taken as the drift in delay time over a 5-minute run at full ratings between the second and seventh minutes of operation.
- The variation of firing time measured at 50% of current pulse amplitude.
- The recovery characteristics are controlled on a sampling basis.

MAXIMUM RECOVERY CHARACTERISTICS

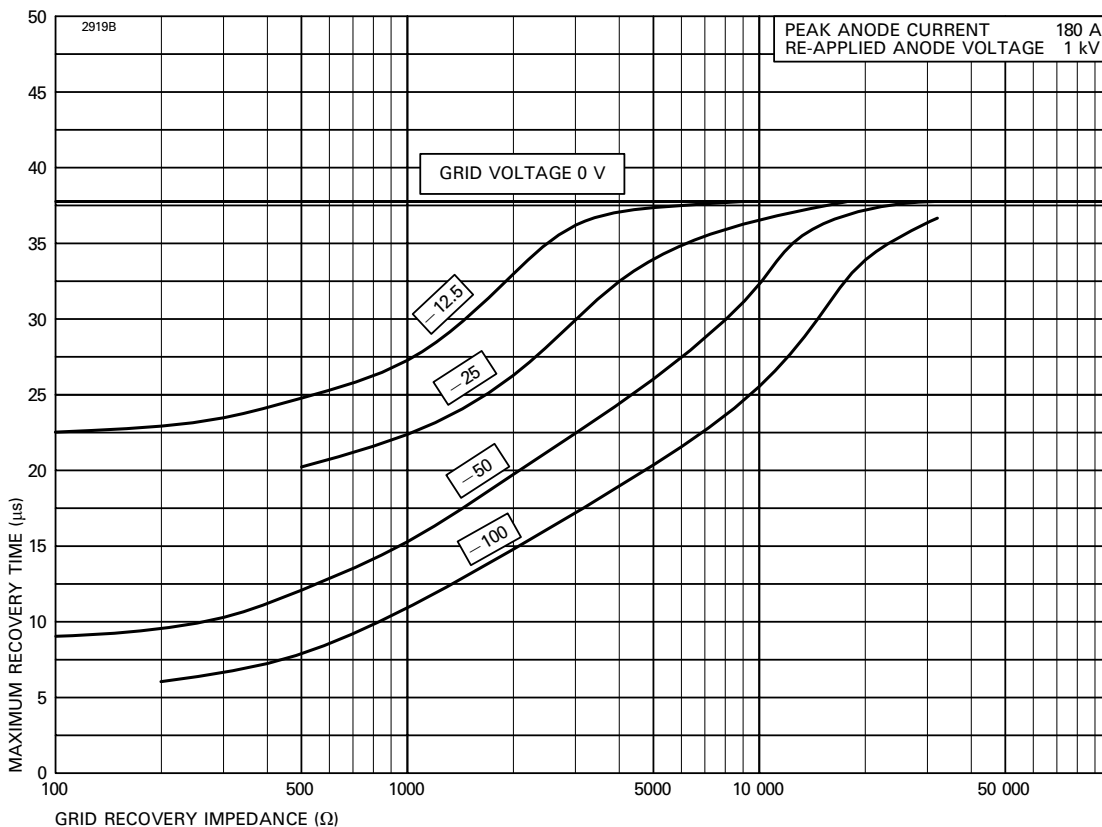

OUTLINE

(All dimensions without limits are nominal)

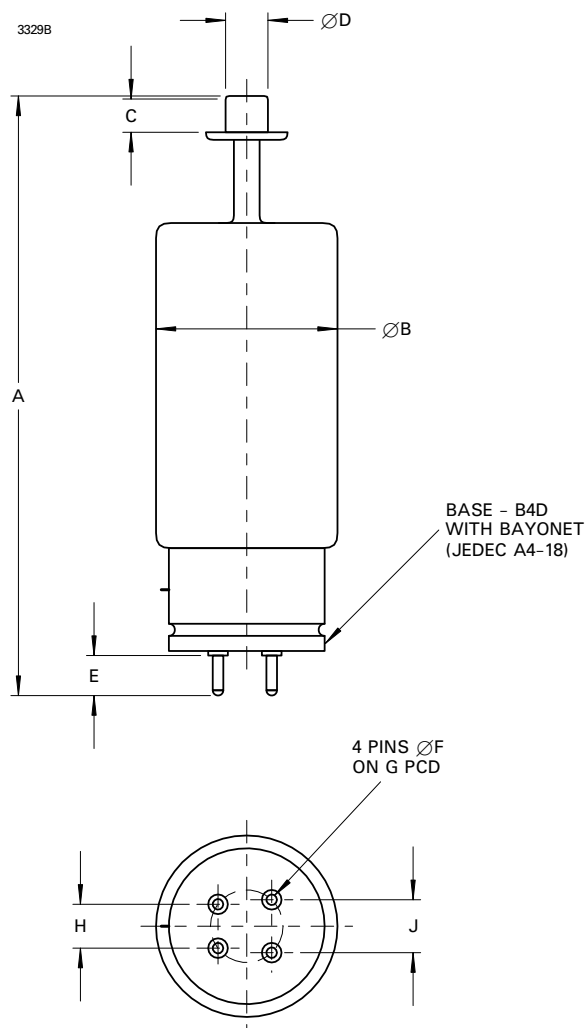

Ref	Millimetres	Inches
A	215.9 ± 6.4	8.500 ± 0.250
B	65.1 max	2.563 max
C	9.53 min	0.375 min
D	14.38 ± 0.18	0.566 ± 0.007
E	15.88	0.625
F	4.750 ± 0.076	0.187 ± 0.003
G	25.4	1.000
H	14.27	0.562
J	19.05	0.750

Inch dimensions have been derived from millimetres.

Base Connections

Pin	Element
1	Grid
2	Heater, cathode
3	Heater
4	Cathode
Top cap	Anode

HEALTH AND SAFETY HAZARDS

Marconi Applied Technologies hydrogen thyratrons are safe to handle and operate, provided that the relevant precautions stated herein are observed. Marconi Applied Technologies does not accept responsibility for damage or injury resulting from the use of electronic devices it produces. Equipment manufacturers and users must ensure that adequate precautions are taken. Appropriate warning labels and notices must be provided on equipments incorporating Marconi Applied Technologies devices and in operating manuals.



High Voltage

Equipment must be designed so that personnel cannot come into contact with high voltage circuits. All high voltage circuits and terminals must be enclosed and fail-safe interlock switches must be fitted to disconnect the primary power supply and discharge all high voltage capacitors and other stored charges before allowing access. Interlock switches must not be bypassed to allow operation with access doors open.



X-Ray Radiation

All high voltage devices produce X-rays during operation and may require shielding. The X-ray radiation from hydrogen thyratrons is usually reduced to a safe level by enclosing the equipment or shielding the thyratron with at least 1.6 mm (¹/₁₆ inch) thick steel panels.

Users and equipment manufacturers must check the radiation level under their maximum operating conditions.

Whilst Marconi Applied Technologies has taken care to ensure the accuracy of the information contained herein it accepts no responsibility for the consequences of any use thereof and also reserves the right to change the specification of goods without notice. Marconi Applied Technologies accepts no liability beyond that set out in its standard conditions of sale in respect of infringement of third party patents arising from the use of tubes or other devices in accordance with information contained herein.