

The data to be read in conjunction with the Hydrogen Thyatron Preamble.

ABRIDGED DATA

Flange mounted hydrogen-filled triode thyatron, positive grid, for pulse operation. A hydrogen reservoir is incorporated. The tube is ruggedised to meet the requirements of airborne applications. Environmental tests applied to the tube comply with those of the CV6022 specification and include linear acceleration at 12 g, and vibration at $\frac{1}{4}$ g minimum acceleration and 150 Hz frequency or at the frequency of maximum resonance in the range between 10 and 150 Hz.

Peak forward anode voltage	20	kV max
Peak anode current	325	A max
Average anode current	500	mA max
Anode heating factor	3.9×10^9	VApps max
Peak output power	2.0	MW max

GENERAL

Electrical

Cathode (connected internally to one end of heater)	oxide coated
Heater voltage	$6.3 \pm 7.5\%$ V
Heater current	10.6 A
Tube heating time (minimum)	3.0 min

Mechanical

Seated height	168.35 mm (6.628 inches) max
Clearance required below mounting flange	31.75 mm (1.250 inch) min
Overall diameter (excluding mounting flange)	65.1 mm (2.563 inches) max
Net weight	340 g (12 ounces) approx
Mounting position	any
Tube connections	see outline
Top cap	BS448-CT3
Top cap connector	MA359

Cooling	natural
--------------------------	---------

PULSE MODULATOR SERVICE MAXIMUM AND MINIMUM RATINGS (Absolute values)

	Min	Max	
Anode			
Peak forward anode voltage (see note 1)	-	20	kV
Peak inverse anode voltage (see note 2)	-	20	kV
Peak anode current	-	325	A
Average anode current	-	500	mA
Rate of rise of anode current (see note 3)	-	1500	A/ μ s
Anode heating factor	-	3.9×10^9	VApps

Grid

Unloaded grid drive pulse voltage (see note 4)	200	-	V
Grid pulse duration	2.0	-	μ s
Rate of rise of grid pulse (see note 3)	180	-	V/ μ s
Peak inverse grid voltage	-	200	V
Loaded grid bias voltage	0	-120	V
Forward impedance of grid drive circuit	-	500	Ω

Cathode

Heater voltage	$6.3 \pm 7.5\%$	-	V
Tube heating time	3.0	-	min

Environmental

Environmental performance	see note 5		
Ambient temperature	-50	+90	$^{\circ}$ C
Altitude	-	3	km
	-	10 000	ft

CHARACTERISTICS

	Min	Typical	Max	
Critical DC anode voltage for conduction (see note 6)	-	0.3	1.0	kV
Anode delay time (see notes 6 and 7)	-	0.3	0.65	μ s
Anode delay time drift (see notes 6 and 8)	-	0.05	0.1	μ s
Time jitter (see notes 6 and 9)	-	5.0	10.0	ns
Recovery time	see note 10 and graph			
Heater current (at 6.3 V)	9.6	10.6	11.6	A
Additional tests	see note 11			

NOTES

1. This is the maximum forward hold-off voltage imposed on the thyatron in a pulse modulator circuit. Tubes are tested at 20 kV peak forward anode voltage, with the charging reactor inductance and pulse forming network capacitance resonant at 1000 pps. For instantaneous starting applications the maximum permissible peak forward voltage is 16 kV; this must not be reached in less than 0.04 s and there must be no overshoot.
2. In pulsed operation the peak inverse anode voltage, exclusive of a spike of 0.05 μ s duration, must not exceed 5.0 kV during the first 25 μ s after the pulse.
3. This rate of rise refers to that part of the leading edge of the pulse between 25% and 75% of the pulse amplitude.
4. Measured with respect to cathode potential.
5. All tubes are subjected to an acceleration of 10 g at 50 Hz before testing. In addition, samples are tested under the following conditions:
 - (a) **Linear Acceleration** - 12 g (min) is applied and maintained for 1 minute at right angles to and in each direction along the major axis of the tube. A heater voltage of 6.3 V is applied during the test.
 - (b) **Resonance Search** - Vibration is applied in two mutually perpendicular directions, one of which is parallel to the longitudinal axis of the tube. The frequency is swept at a rate not exceeding one octave per minute between 10 and 150 Hz, with accelerations of $\frac{1}{4}$ g (min). All resonances detectable visually or electrically are noted for information and also for use in test (c). Normal operating voltages are applied during the test.
 - (c) **Vibration Fatigue** - Each tube is subjected to vibration for two periods of ten hours. In one period the direction of vibration is parallel to the longitudinal axis of the tube, and in the other the direction is perpendicular to the longitudinal axis of the tube. The acceleration is $\frac{1}{4}$ g and the frequency is that of the strongest resonance detected during the resonance search. If no resonances were detected in the search, then a frequency of 150 Hz is used. A heater voltage of 6.3 V is applied during the test.

Tubes must pass operational tests after the above procedure has been completed.

6. The typical figures are obtained on test using conditions of minimum grid drive. Improved performance can be expected by increasing the grid drive.
7. The time interval between a point on the leading edge of the unloaded grid pulse at 25% of the pulse amplitude and the point where anode conduction takes place.
8. Normally taken as the drift in delay time over a 5-minute run at full ratings between the second and seventh minutes of operation.
9. The variation of firing time measured at 50% of current pulse amplitude.
10. The recovery characteristics are controlled on a sampling basis.
11. In addition to operational testing at pulse repetition rates of 800 and 1000 pps on all tubes, an additional test at 2500 pps, 12.5 kV, is performed on a sampling basis.

HEALTH AND SAFETY HAZARDS

Marconi Applied Technologies hydrogen thyratrons are safe to handle and operate, provided that the relevant precautions stated herein are observed. Marconi Applied Technologies does not accept responsibility for damage or injury resulting from the use of electronic devices it produces. Equipment manufacturers and users must ensure that adequate precautions are taken. Appropriate warning labels and notices must be provided on equipments incorporating Marconi Applied Technologies devices and in operating manuals.



High Voltage

Equipment must be designed so that personnel cannot come into contact with high voltage circuits. All high voltage circuits and terminals must be enclosed and fail-safe interlock switches must be fitted to disconnect the primary power supply and discharge all high voltage capacitors and other stored charges before allowing access. Interlock switches must not be bypassed to allow operation with access doors open.



X-Ray Radiation

All high voltage devices produce X-rays during operation and may require shielding. The X-ray radiation from hydrogen thyratrons is usually reduced to a safe level by enclosing the equipment or shielding the thyatron with at least 1.6 mm ($\frac{1}{16}$ inch) thick steel panels.

Users and equipment manufacturers must check the radiation level under their maximum operating conditions.

MAXIMUM RECOVERY CHARACTERISTICS

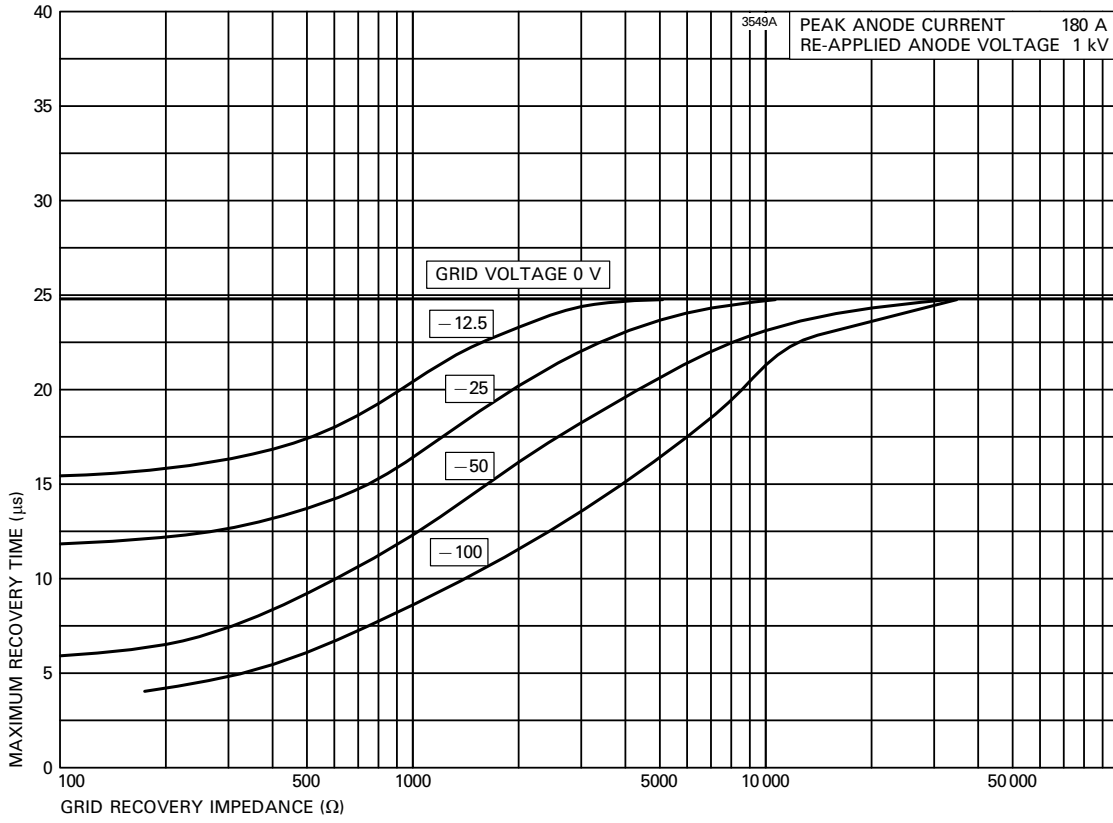

OUTLINE

(All dimensions without limits are nominal)

7282

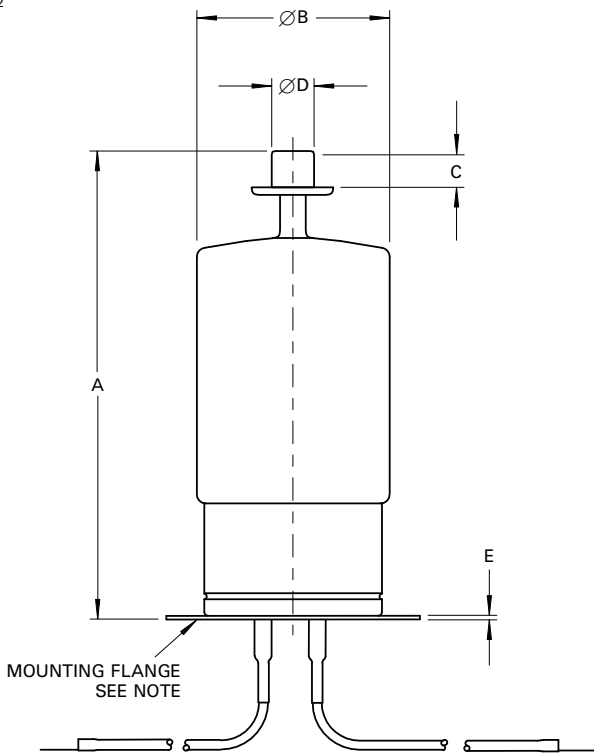

Ref	Millimetres	Inches
A	162.00 ± 6.35	6.378 ± 0.250
B	65.10 max	2.563 max
C	9.53 min	0.375 min
D	14.38 ± 0.18	0.566 ± 0.007
E	1.6	0.063
F	88.9	3.500
G	76.2	3.000
H	5.0	0.197
J	152.4 min	6.000 min
K	6.0	0.236

Inch dimensions have been derived from millimetres.

Outline Note

The mounting flange is the connection for the cathode and the heater return.

HEATER LEAD (YELLOW)
J LONG, TAG TO SUIT ØK

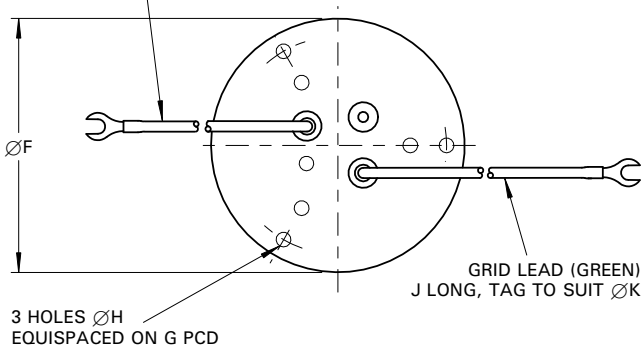

Whilst Marconi Applied Technologies has taken care to ensure the accuracy of the information contained herein it accepts no responsibility for the consequences of any use thereof and also reserves the right to change the specification of goods without notice. Marconi Applied Technologies accepts no liability beyond that set out in its standard conditions of sale in respect of infringement of third party patents arising from the use of tubes or other devices in accordance with information contained herein.